

## Calibrating TR-398 Issue-2 and Mesh on a 4-Chamber Setup

**Goal:** Setup and run a TR-398 Issue 2 test for an AP using a 6-radio version of the LANforge CT523c or similar system in order to test how well the AP can handle the various test cases specified in the TR-398 Issue 2 test document.

In this test scenario, a LANforge cluster (of a 1 523c and 3 521as) is used to emulate different station and AP scenarios and generate and receive traffic with an AP. This example assumes user has some experience with Chamber View, and has an appropriate LANforge system (fit for TR-398 Issue 2), programmable attenuators like the CT714 and some isolation chambers like the CT820a and CT840a. Please contact support@candelatech.com for assistance in setting up the TR-398 testbed.

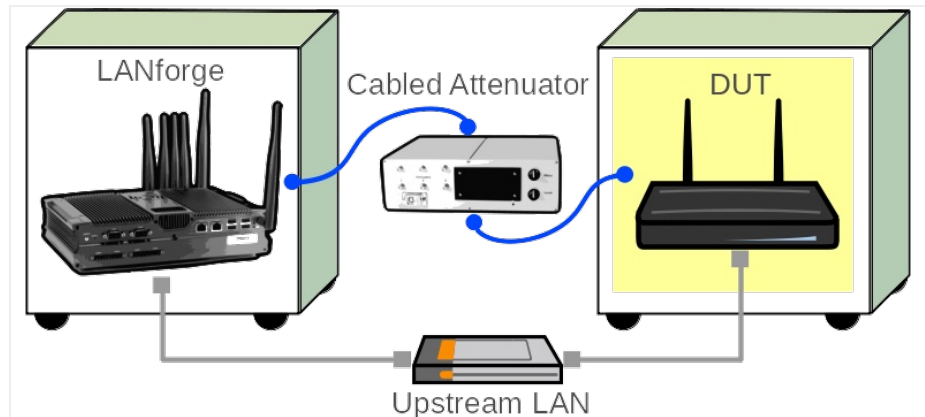

1. Configure Chamber View for TR-398 and Similar Tests.

- A. Open Chamber View by clicking on the 'Chamber View' button in the LANforge-GUI. If you have an appropriate scenario already created, please skip to the next section, otherwise you will need to build a scenario that matches your system. You can right-click in Chamber View to create various objects. This cookbook will use the Chamber View scenario seen below.

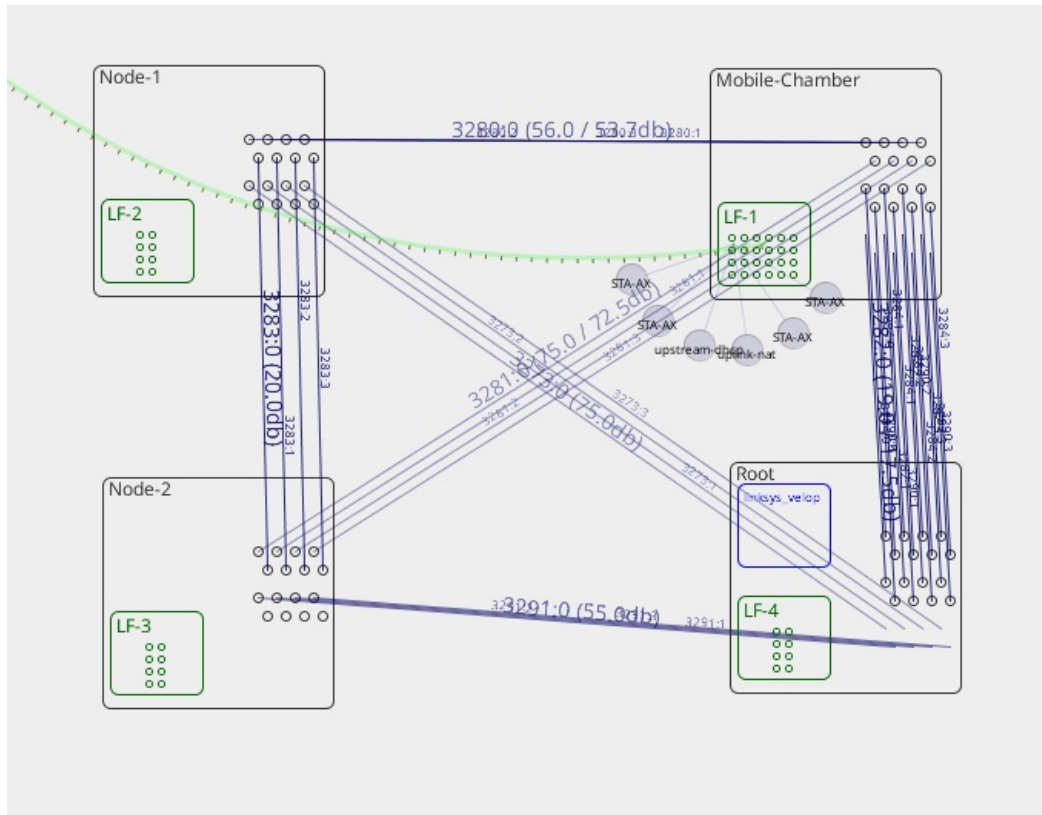

- B. Create a Device Under Test (DUT) Profile that matches your AP. The BSSID is important to configure so that LANforge knows when it is connected to the correct AP. In a mesh scenario, you will create 3 DUT objects, one for each of the mesh AP chambers.

**Create/Modify DUT**

Name	linksys_velop	Image file	NONE	Choose Image	x
SW Info		HW Info		Model Number	
Serial Number		Serial port		API version	0
WAN		LAN			
SSID-1	velop_lanforge	Password-1	lanforge	BSSID-1	d8:ec:5e:7a:21:e8 <input type="checkbox"/> WEP <input type="checkbox"/> WPA <input checked="" type="checkbox"/> WPA2 <input type="checkbox"/> WPA3 <input type="checkbox"/> 802.11r <input type="checkbox"/> EAP-TTLS <input type="checkbox"/> EAP-PEAP
SSID-2	velop_lanforge	Password-2	lanforge	BSSID-2	d8:ec:5e:7a:21:e9 <input type="checkbox"/> WEP <input type="checkbox"/> WPA <input checked="" type="checkbox"/> WPA2 <input type="checkbox"/> WPA3 <input type="checkbox"/> 802.11r <input type="checkbox"/> EAP-TTLS <input type="checkbox"/> EAP-PEAP
SSID-3		Password-3		BSSID-3	00:00:00:00:00:00 <input type="checkbox"/> WEP <input type="checkbox"/> WPA <input type="checkbox"/> WPA2 <input type="checkbox"/> WPA3 <input type="checkbox"/> 802.11r <input type="checkbox"/> EAP-TTLS <input type="checkbox"/> EAP-PEAP
SSID-4		Password-4		BSSID-4	00:00:00:00:00:00 <input type="checkbox"/> WEP <input type="checkbox"/> WPA <input type="checkbox"/> WPA2 <input type="checkbox"/> WPA3 <input type="checkbox"/> 802.11r <input type="checkbox"/> EAP-TTLS <input type="checkbox"/> EAP-PEAP
SSID-5		Password-5		BSSID-5	00:00:00:00:00:00 <input type="checkbox"/> WEP <input type="checkbox"/> WPA <input type="checkbox"/> WPA2 <input type="checkbox"/> WPA3 <input type="checkbox"/> 802.11r <input type="checkbox"/> EAP-TTLS <input type="checkbox"/> EAP-PEAP
SSID-6		Password-6		BSSID-6	00:00:00:00:00:00 <input type="checkbox"/> WEP <input type="checkbox"/> WPA <input type="checkbox"/> WPA2 <input type="checkbox"/> WPA3 <input type="checkbox"/> 802.11r <input type="checkbox"/> EAP-TTLS <input type="checkbox"/> EAP-PEAP
SSID-7		Password-7		BSSID-7	00:00:00:00:00:00 <input type="checkbox"/> WEP <input type="checkbox"/> WPA <input type="checkbox"/> WPA2 <input type="checkbox"/> WPA3 <input type="checkbox"/> 802.11r <input type="checkbox"/> EAP-TTLS <input type="checkbox"/> EAP-PEAP
SSID-8		Password-8		BSSID-8	00:00:00:00:00:00 <input type="checkbox"/> WEP <input type="checkbox"/> WPA <input type="checkbox"/> WPA2 <input type="checkbox"/> WPA3 <input type="checkbox"/> 802.11r <input type="checkbox"/> EAP-TTLS <input type="checkbox"/> EAP-PEAP
EAP-ID		Mgt IP	0.0.0.0		
Num Ant Radio 1	0	Num Ant Radio 2	0	Num Ant Radio 3	0
<input type="checkbox"/> Active <input checked="" type="checkbox"/> Provides DHCP on LAN <input type="checkbox"/> DHCP Client <input type="checkbox"/> Provides DHCP on WAN <input checked="" type="checkbox"/> AP DUT					
Notes					
<div style="border: 1px solid gray; height: 100px;"></div>					
<input type="button" value="Apply"/> <input type="button" value="OK"/> <input type="button" value="Cancel"/>					

- C. Create a chamber object to hold the DUT, and add the DUT to that chamber. If you have no chambers, you can create a fake chamber, but your test will not be isolated and may not function as desired. The turntable configuration is different for different models of chambers, this example (bare IP address) is for the CT840a chamber.

**Create/Modify Chamber**

Name: TR-398 Width: 150 Height: 150  
Chamber Type: 2D Large (3) Isolation: 80 Speed (rpm): 3.0  
Turntable Type: CT840A (2) Turntable: 192.168.100.10 Position (deg): 0.0 Tilt (deg): 0.0  
Managed By: 1 (mobilestations) Turntable Rpt: Position: 0.0 Tilt: 0.0 RPM: 3.0 Connected  Virtual  Open  
DUT-1: TR398-DUT DUT-2:   
DUT-3: DUT-4:   
LANforge-1: None LANforge-2: None  
LANforge-3: None LANforge-4: None

Int CX A	Int CX B	Int Atten	Ext CX A	Ext CX B	Ext Atten	Atten Floor	Zero-Atten RSSI 2.4Ghz	Zero-Atten RSSI 5Ghz
						Cable (100 ddb)	None (0 ddb)	None (0 ddb)
						Cable (100 ddb)	None (0 ddb)	None (0 ddb)
						Cable (100 ddb)	None (0 ddb)	None (0 ddb)
						Cable (100 ddb)	None (0 ddb)	None (0 ddb)
						Cable (100 ddb)	None (0 ddb)	None (0 ddb)
						Cable (100 ddb)	None (0 ddb)	None (0 ddb)
						Cable (100 ddb)	None (0 ddb)	None (0 ddb)
						Cable (100 ddb)	None (0 ddb)	None (0 ddb)
						Cable (100 ddb)	None (0 ddb)	None (0 ddb)
						Cable (100 ddb)	None (0 ddb)	None (0 ddb)
						Cable (100 ddb)	None (0 ddb)	None (0 ddb)
						Cable (100 ddb)	None (0 ddb)	None (0 ddb)
						Cable (100 ddb)	None (0 ddb)	None (0 ddb)
						Cable (100 ddb)	None (0 ddb)	None (0 ddb)
						Cable (100 ddb)	None (0 ddb)	None (0 ddb)
						Cable (100 ddb)	None (0 ddb)	None (0 ddb)
						Cable (100 ddb)	None (0 ddb)	None (0 ddb)
						Cable (100 ddb)	None (0 ddb)	None (0 ddb)
						Cable (100 ddb)	None (0 ddb)	None (0 ddb)
						Cable (100 ddb)	None (0 ddb)	None (0 ddb)
						Cable (100 ddb)	None (0 ddb)	None (0 ddb)
						Cable (100 ddb)	None (0 ddb)	None (0 ddb)
						Cable (100 ddb)	None (0 ddb)	None (0 ddb)
						Cable (100 ddb)	None (0 ddb)	None (0 ddb)
						Cable (100 ddb)	None (0 ddb)	None (0 ddb)
						Cable (100 ddb)	None (0 ddb)	None (0 ddb)
						Cable (100 ddb)	None (0 ddb)	None (0 ddb)

Sync Apply OK Cancel

- D. Create a chamber object to hold the LANforge system, and add the LANforge to it. Add connections from this chamber to the DUT chamber, specifying the proper Attenuator modules. Please note we use the 'OTA' attenuation floor since we have OTA connection between DUT and antennas inside the DUT chamber. Please view our other cookbook on [setting up attenuator connections in LANforge](#).

**Create/Modify Chamber**

Name: MobileStations Width: 150 Height: 150  
Chamber Type: Medium (1) Isolation: 80 Speed (rpm): 0.0  
Turntable Type: CT850A (0) Turntable: Position (deg): 0.0 Tilt (deg): 0.0  
Managed By: None Turntable Rpt: Position: 0.0 Tilt: 0.0 RPM: 0.0  Virtual  Open  
DUT-1: DUT-2:   
DUT-3: DUT-4:   
LANforge-1: 1 (mobilestations) LANforge-2: None  
LANforge-3: None LANforge-4: None

Int CX A	Int CX B	Int Atten	Ext CX A	Ext CX B	Ext Atten	Atten Floor	Zero-Atten RSSI 2.4Ghz	Zero-Atten RSSI 5Ghz
			Chamber.MobileStations.0	Chamber.TR-398.0	1.1.85.3	OTA (0 ddb)	None (0 ddb)	None (0 ddb)
			Chamber.MobileStations.1	Chamber.TR-398.1	1.1.85.2	OTA (0 ddb)	None (0 ddb)	None (0 ddb)
			Chamber.MobileStations.2	Chamber.TR-398.2	1.1.85.1	OTA (0 ddb)	None (0 ddb)	None (0 ddb)
			Chamber.MobileStations.3	Chamber.TR-398.3	1.1.85.0	OTA (0 ddb)	None (0 ddb)	None (0 ddb)
			Chamber.MobileStations.4	Chamber.TR-398.4	1.1.1002.3	OTA (0 ddb)	None (0 ddb)	None (0 ddb)
			Chamber.MobileStations.5	Chamber.TR-398.5	1.1.1002.2	OTA (0 ddb)	None (0 ddb)	None (0 ddb)
			Chamber.MobileStations.6	Chamber.TR-398.6	1.1.1002.1	OTA (0 ddb)	None (0 ddb)	None (0 ddb)
			Chamber.MobileStations.7	Chamber.TR-398.7	1.1.1002.0	OTA (0 ddb)	None (0 ddb)	None (0 ddb)
						Cable (100 ddb)	None (0 ddb)	None (0 ddb)
						Cable (100 ddb)	None (0 ddb)	None (0 ddb)
						Cable (100 ddb)	None (0 ddb)	None (0 ddb)
						Cable (100 ddb)	None (0 ddb)	None (0 ddb)
						Cable (100 ddb)	None (0 ddb)	None (0 ddb)
						Cable (100 ddb)	None (0 ddb)	None (0 ddb)
						Cable (100 ddb)	None (0 ddb)	None (0 ddb)
						Cable (100 ddb)	None (0 ddb)	None (0 ddb)
						Cable (100 ddb)	None (0 ddb)	None (0 ddb)
						Cable (100 ddb)	None (0 ddb)	None (0 ddb)
						Cable (100 ddb)	None (0 ddb)	None (0 ddb)
						Cable (100 ddb)	None (0 ddb)	None (0 ddb)
						Cable (100 ddb)	None (0 ddb)	None (0 ddb)
						Cable (100 ddb)	None (0 ddb)	None (0 ddb)

Sync Apply OK Cancel

- E. Configure a Chamber View Scenario and add the STA profile (mapped to desired wiphyX radio and DUT). Add an upstream profile mapped to DUT LAN side (or possibly WAN side if that is more appropriate for your DUT).

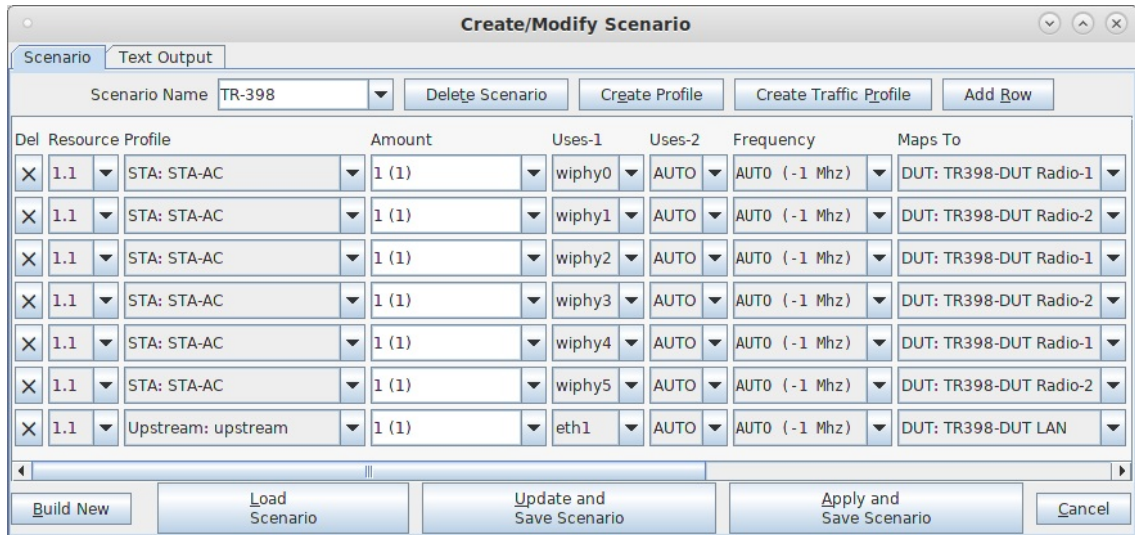

2. For TR398 tests, the DUT AP's front should face the antennas for the Group-1 stations. Or, optionally, one can use the Advanced configuration tab to specify the default turntable angle for non rotational tests.
3. Open Chamber View by clicking on the 'Chamber View' button in the LANforge-GUI. Load appropriate scenario. Apply the Scenario, then Build the scenario.

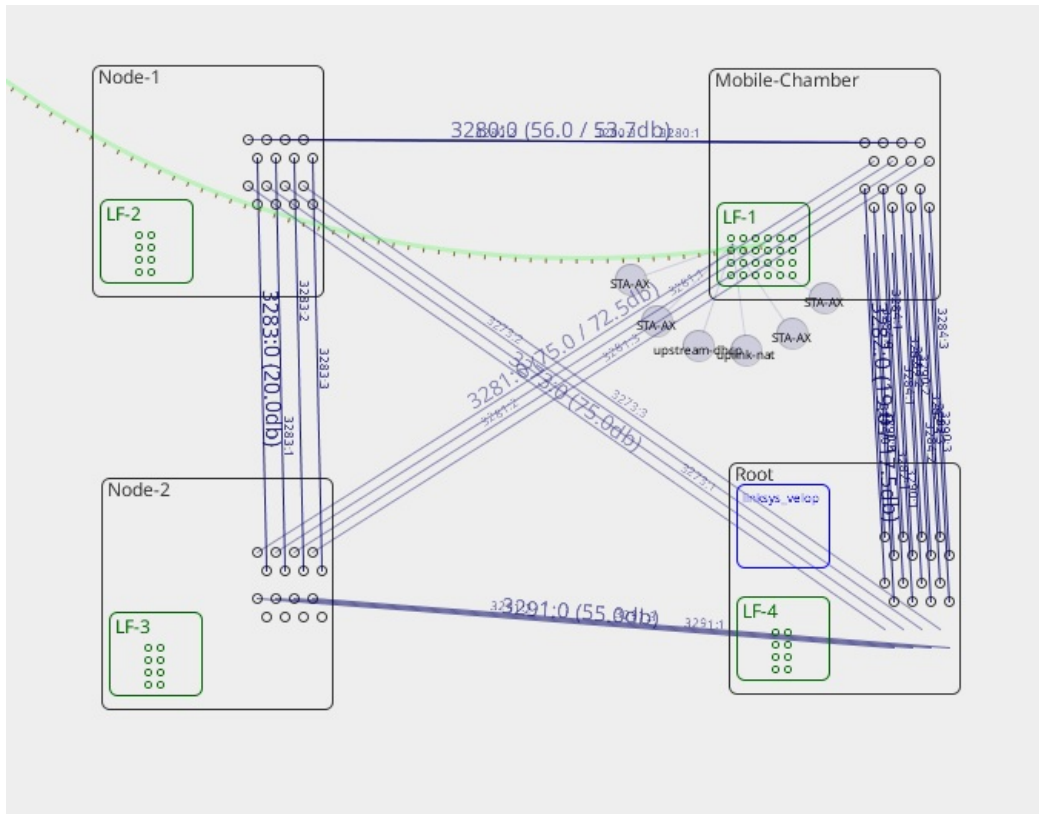

4. Select the **TR-398-Issue-2** test from Tests dropdown in the right panel. Then click Run Test. The following window below should pop up. In the Settings tab, set slots 'Selected DUT 5G', 'Selected DUT 2G', and 'Selected DUT 6G' the according BSSIDs found in the 'Root' Chamber. Also set the upstream port. In this example, the upstream port is the eth2 port on the LANforge in Mobile Stations chamber.

**TR-398 Issue 2 Automated Test (cv-inst-1)**

Per-Test Config 1 | Per-Test Config 2 | Per-Test Config 3 | **Advanced Configuration** | Report Configuration | TR398-Issue3

Settings | Virtual Sta Radio Settings | 802.11AX Settings | 802.11AX Settings 2 | Mesh Settings | Mesh Settings 2

Selected DUT 5G: linksys\_velop\_velop\_lanforge d8:ec:5e:7a:21:e9 (2) | Upstream Port: 1.1.2 eth2

Selected DUT 2G: linksys\_velop ve **Select 5Ghz DUT to be used in this test.** | Turn-Table-Chamber:

Selected DUT 6G: linksys\_velop\_velop\_lanforge d8:ec:5e:7a:21:e9 (2) | Extra Download Path-loss: 0 (0)

2.4Ghz 2m RSSI: -26 | 5Ghz 2m RSSI: -30

Skip 2.4Ghz Tests  
 Skip 5Ghz Tests  
 Skip 6Ghz Tests  
 Skip N/AC Tests  
 Skip AX Tests  
 Use Issue-3 Behaviour  
 Allow-11w (MFP/PMF)

TR-398 Tests to Run:      Estimated Test Duration: 3 m

Calibrate 802.11AX Radios       Calibrate 802.11AC Radios       Calibrate Group Throughput  
 Calibrate 802.11AX Attenuators       Calibrate 802.11AC Attenuators  
 Calibrate Mesh Root Attenuators       Calibrate Mesh Node-1 Attenuators       Calibrate Mesh Root to Node-1 Attenuators  
 Calibrate Mesh Node-2 Attenuators       Calibrate Mesh Node-1 to Node-2 Attenuators       Calibrate Mesh Root to Node-2 Attenuators  
 6.1.1 Receiver Sensitivity       6.2.6 Latency       6.4.2 Multiple Assoc Stability  
 6.2.1 Maximum Connection       6.2.7 Quality of Service       6.4.3 Downlink MU-MIMO  
 6.2.2 Maximum Throughput       6.3.1 Range Versus Rate       6.4.4 Multicast  
 6.2.3 Airtime Fairness       6.3.2 Spatial Consistency       6.5.1 Long Term Stability  
 6.2.4 Dual-Band Throughput       6.3.3 AX Peak Performance       6.5.2 AP Coexistence  
 6.2.5 Bi-Directional Throughput       6.4.1 Multiple STAs Performance       6.5.3 Automatic Channel Selection  
 8.1.1 Mesh Backhaul RvR       8.1.2 Mesh Backhaul Node-2 RvR       8.2.1 Mesh Roam Time

 
  
 Another Iteration  
 Pause  

5. Configure the Virtual Sta Radio Settings tab.

- A. Select the Virtual Sta Radio Settings tab. This tab is for radios that can have virtual stations on them (either AC, N, some AX). Notice that there are 3 groups here, this will be the 3 slots of radios (Slots 2, 3, 4) in the Mobile Clients Chamber. Visit the pictures in the next 2 steps to see close ups of the attenuator diagram that has the slots. Slot 2 (Group 0) has W0 and W1 (wiphy0 and wiphy1). Slot 3 (Group 1) has W2 and W3 (wiphy2 and wiphy3). Slot 4 (Group 2) has W4 and W5 (wiphy4 and wiphy5). Leave the '2.4Ghz RSSI 0 Atten' and '5Ghz RSSI 0 Atten' blank, those will be auto calculated when we calibrate the attenuators. Lastly, fill out the attenuator modules column (with the correct serial numbers that relate to each group). All these attenuators will be the TR-398 section of the attenuator stack. In this case, those are attenuators T1, T2 and T3. These attenuators are also all connecting the **Node 3/Root** chamber to the **Mobile Clients** chamber. Match the according attenuator to each group on the attenuator diagram. Fill out all the dropdowns under 'Attenuator Modules' for ports 0-3 on the matching attenuator. Select the 'Use Virtual AX Stations' checkbox.

Radio	2.4Ghz RSSI 0 Atten	5Ghz RSSI 0 Atten	Attenuator Modules	
<b>Group: 0</b>				
5Ghz	1.1.4 wiphy0	-23	-44	1.1.3282.0
2.4Ghz	1.1.5 wiphy1	-23	-44	1.1.3282.1
6Ghz		-23	-44	1.1.3282.2
		-23	-44	1.1.3282.3
<b>Group: 1</b>				
5Ghz	1.1.6 wiphy2	-23	-43	1.1.3290.0
2.4Ghz	1.1.7 wiphy3	-23	-43	1.1.3290.1
6Ghz		-23	-43	1.1.3290.2
		-23	-43	1.1.3290.3
<b>Group: 2</b>				
5Ghz	1.1.8 wiphy4	-30	-47	1.1.3284.0
2.4Ghz	1.1.9 wiphy5	-30	-47	1.1.3284.1
6Ghz		-30	-47	1.1.3284.2
		-30	-47	1.1.3284.3

Use Virtual AX Stations    Use AX Radios for AC tests

Start   Skip    Another Iteration    Pause   Cancel

- B. Below is the attenuator diagram of the 4-chamber setup in the example. Another name for the Node-3 Chamber is the Root chamber.

# Three Node Mesh + TR-398



## Programmable Attenuators

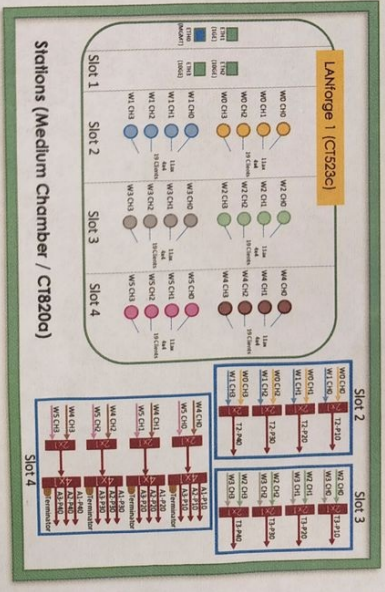
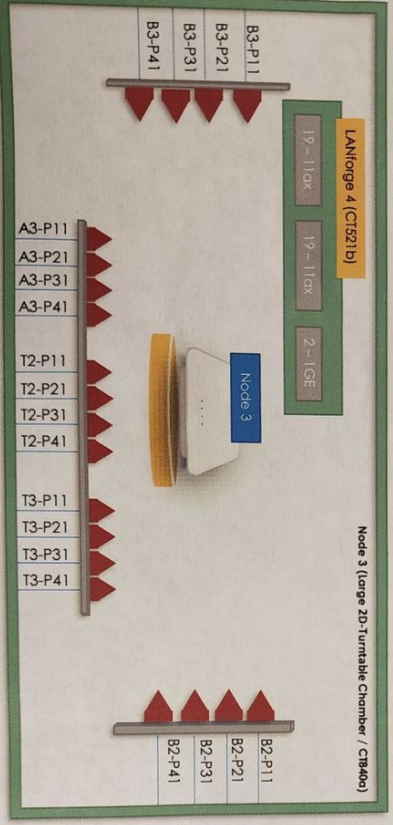
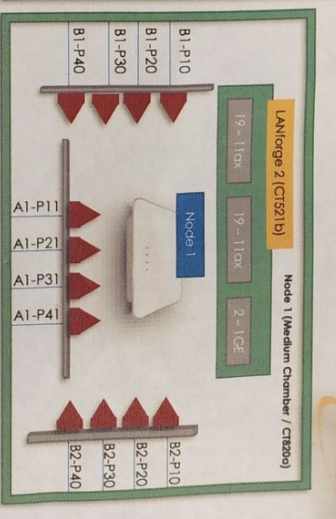
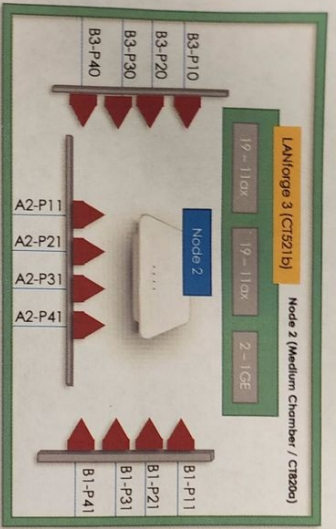

C. Below is a closer look at the bottom right box of the attenuator diagram in the step above.

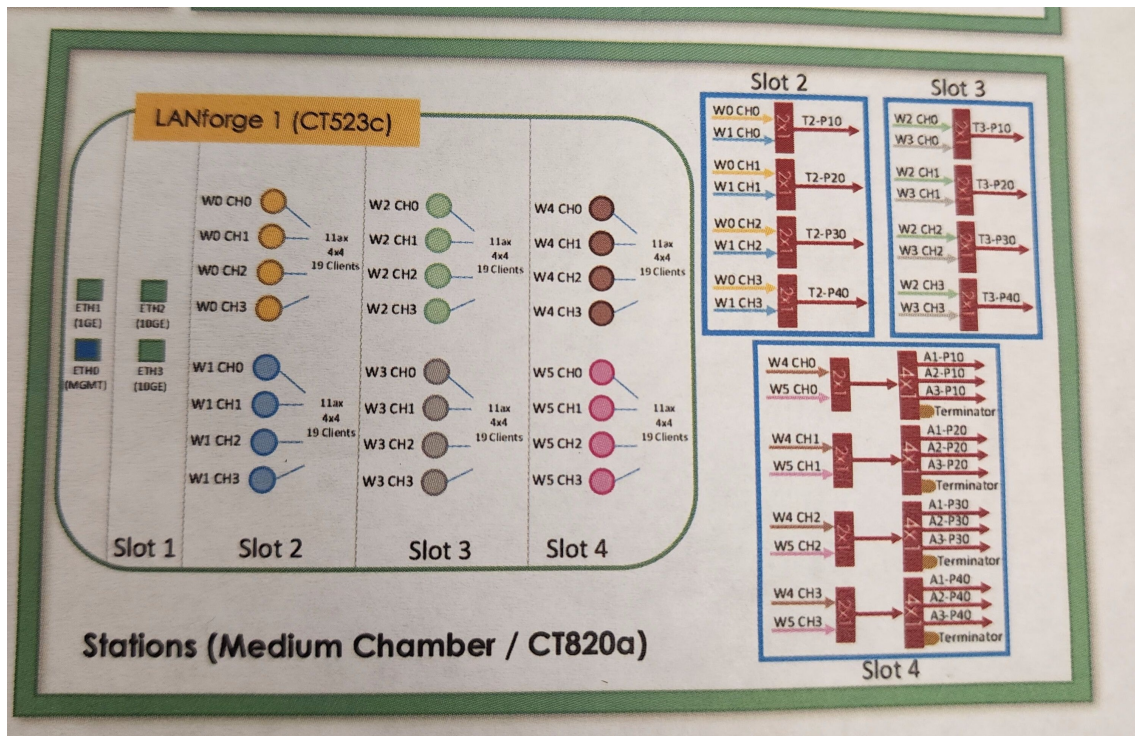

D. Below are the serial numbers of the attenuator stack. They are stacked in the same order as the attenuator diagram.





6. Configure the 802.11 AX Settings (1 & 2) tabs. Please contact [support@candelatech.com](mailto:support@candelatech.com) for assistance in filling out these tabs. These settings only apply to AX capable radios that do not support virtual stations.
7. Configure the Mesh Settings and Mesh Settings 2 tabs. If the test bed being setup has no need for Mesh, please skip this step.

- A. Select the Mesh Settings tab. The picture below is a final version of the calibrated mesh setup. In an uncalibrated version (yours), all the rows in the 'RSSI 0 Atten' columns will be empty. Fill out select the 2.4Ghz and 5Ghz BSSIDs for both Node 1 and Node 2 Chambers in the top section. Fill out the 'Atten Modules' column for each group (using ports 0-3 for each attenuator). To find out the correct attenuator, trace the attenuator diagram to find out which attenuator connects which 2 Chambers. In Group 1 (in this section), use the attenuator and radios used in 'Group 2' of the Virtual Sta Radio Settings tab. This attenuator is both TR398 and Access (A3/T1), so it belongs in both Virtual Sta Radio Settings and Mesh Settings

**TR-398 Issue 2 Automated Test (cv-inst-1)**

Per-Test Config 1 | Per-Test Config 2 | Per-Test Config 3 | **Advanced Configuration** | Report Configuration | TR398-Issue3

Settings | Virtual Sta Radio Settings | 802.11AX Settings | 802.11AX Settings 2 | **Mesh Settings** | Mesh Settings 2

Node-1 DUT 5G: linksys\_velop\_velop\_Janforge d8:ec:5e:7a:21:e9 (2)

Node-1 DUT 2G: linksys\_velop\_velop\_Janforge d8:ec:5e:7a:21:e9 (2)

Node-2 DUT 5G: linksys\_velop\_velop\_Janforge d8:ec:5e:7a:21:e9 (2)

Node-2 DUT 2G: linksys\_velop\_velop\_Janforge d8:ec:5e:7a:21:e9 (2)

Use 2-band pass/fail

Background Scan Module: simple | RSSI Threshold: -65

Short Interval: 30 | Long Interval: 300

Radio	2.4Ghz RSSI 0 Atten	5Ghz RSSI 0 Atten	Attenuator Modules	
<b>Group 0: Root to Node-1</b>				
	-49	-63	1.1.3273.0	
	-49	-63	1.1.3273.1	
	-49	-63	1.1.3273.2	
	-49	-63	1.1.3273.3	
<b>Group 1: Mobile Station to Root</b>				
5Ghz	1.1.9 wiphy5	-30	-47	1.1.3284.0
2.4Ghz	1.1.8 wiphy4	-30	-47	1.1.3284.1
		-30	-47	1.1.3284.2
		-30	-47	1.1.3284.3
<b>Group 2: Mobile Station to Node-1</b>				
		-45	-38	1.1.3280.0
		-45	-38	1.1.3280.1
		-45	-38	1.1.3280.2
		-45	-38	1.1.3280.3

Another Iteration
  Pause

B. Fill out the Mesh Settings 2 tab similarly to Mesh Settings 1

TR-398 Issue 2 Automated Test (cv-inst-1)

Per-Test Config 1 | Per-Test Config 2 | Per-Test Config 3 | Advanced Configuration | Report Configuration | TR398-Issue3

Settings | Virtual Sta Radio Settings | 802.11AX Settings | 802.11AX Settings 2 | Mesh Settings | Mesh Settings 2

2.4Ghz RSSI 0 Atten | 5Ghz RSSI 0 Atten | Attenuator Modules

Group 3: Mobile Station to Node-2

-33	-49	1.1.3281.0
-33	-49	1.1.3281.1
-33	-49	1.1.3281.2
-33	-49	1.1.3281.3

Group 4: Node-1 to Node-2

-38	-51	1.1.3283.0
-38	-51	1.1.3283.1
-38	-51	1.1.3283.2
-38	-51	1.1.3283.3

Group 5: Root to Node-2

-41	-46	1.1.3291.0
-41	-46	1.1.3291.1
-41	-46	1.1.3291.2
-41	-46	1.1.3291.3

Start | Skip |  Another Iteration |  Pause | Cancel

8. Click on the Advanced Configuration tab. Set 2.4GHz channel and 5GHz channel to '-1' / AUTO. AUTO won't work for all cases (like the ap-coex test), but will work for most of them.

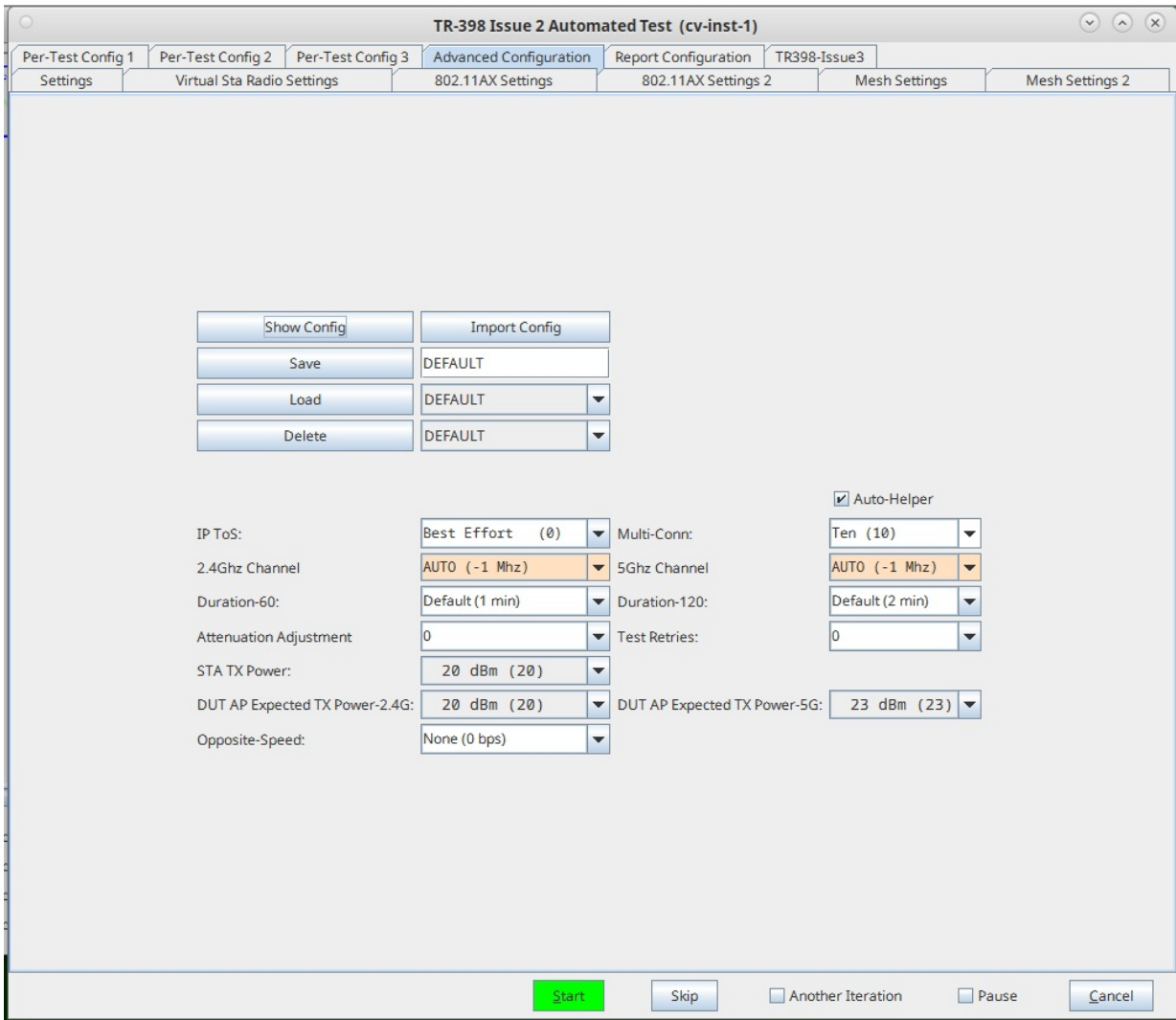

9. Calibrate Zero Attenuation RSSI for all chamber to chamber connections. This also verifies attenuators are connected and functioning as expected.
  - A. Start by setting the LANforge in the center of all the chambers, with all the antennae pointing directly to the LANforge. We are calculating 0 atten against the LANforge.
  - B. Calibrate the 802.11AC attenuators. Only select this checkbox to ensure that the calibration goes OK.



C. In the image below, run each of the checked boxes **one** at a time, until all are run.

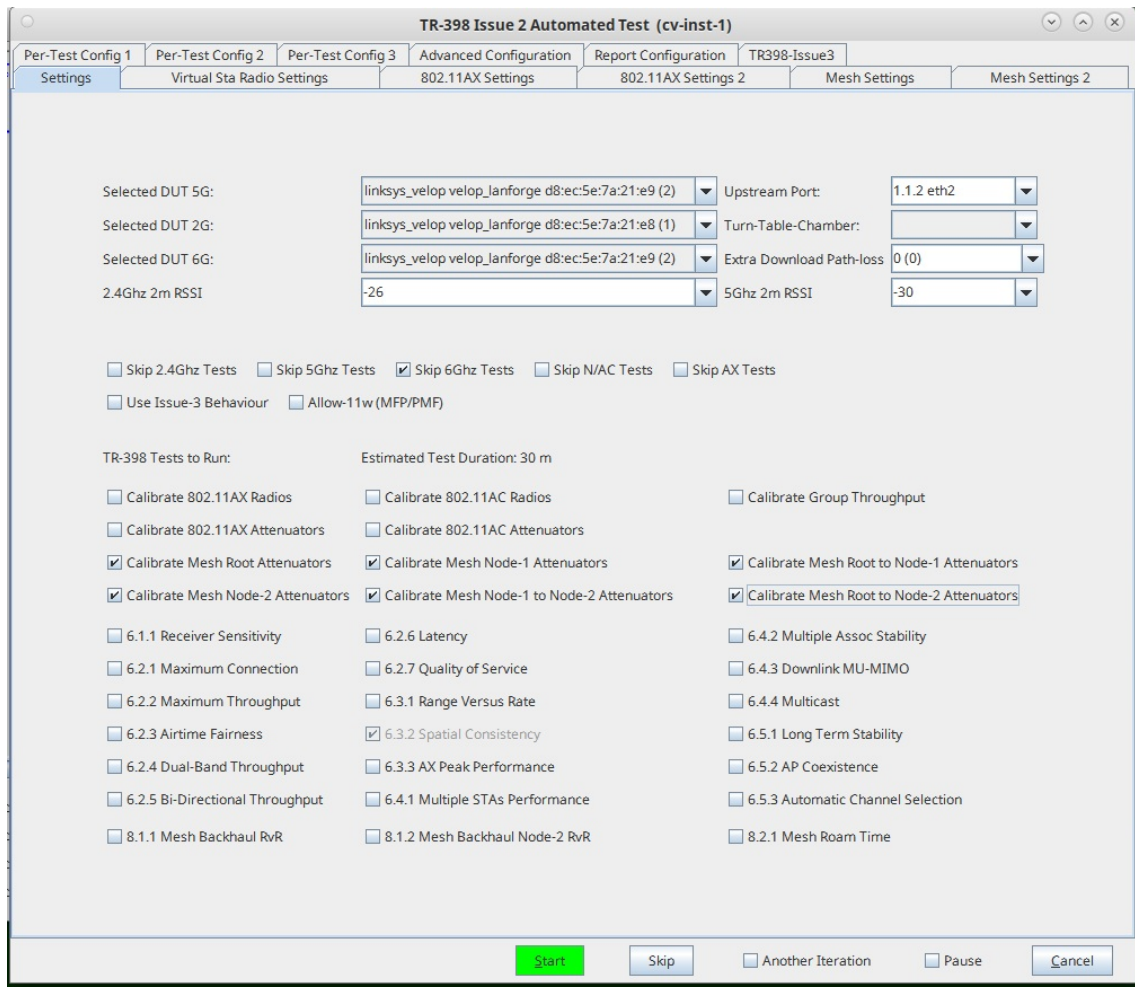

10. At this point, all the 0 Atten values should be filled out (In Virtual Sta Radio Settings and Mesh Settings 1 & 2 tabs).

11. Run a TR-398 Issue 2 throughput test. Select the 6.2.2 Maximum Throughput checkbox to run the test. After verifying the throughput test is working as expected, select and run other tests as desired.

**TR-398 Issue 2 Automated Test (cv-inst-1)**

Per-Test Config 1 | Per-Test Config 2 | Per-Test Config 3 | Advanced Configuration | Report Configuration | TR398-Issue3

Settings | Virtual Sta Radio Settings | 802.11AX Settings | 802.11AX Settings 2 | Mesh Settings | Mesh Settings 2

Selected DUT 5G: linksys\_velop\_velop\_lanforge d8:ec:5e:7a:21:e9 (2) | Upstream Port: 1.1.2.eth2

Selected DUT 2G: Select 5Ghz DUT to be used in this test. 21:e8 (1) | Turn-Table-Chamber:

Selected DUT 6G: linksys\_velop\_velop\_lanforge d8:ec:5e:7a:21:e9 (2) | Extra Download Path-loss: 0 (0)

2.4Ghz 2m RSSI: -26 | 5Ghz 2m RSSI: -30

Skip 2.4Ghz Tests    Skip 5Ghz Tests    Skip 6Ghz Tests    Skip N/Ac Tests    Skip AX Tests

Use Issue-3 Behaviour    Allow-11w (MFP/PMF)

TR-398 Tests to Run:      Estimated Test Duration: 6 m

<input type="checkbox"/> Calibrate 802.11AX Radios	<input type="checkbox"/> Calibrate 802.11AC Radios	<input type="checkbox"/> Calibrate Group Throughput
<input type="checkbox"/> Calibrate 802.11AX Attenuators	<input type="checkbox"/> Calibrate 802.11AC Attenuators	
<input type="checkbox"/> Calibrate Mesh Root Attenuators	<input type="checkbox"/> Calibrate Mesh Node-1 Attenuators	<input type="checkbox"/> Calibrate Mesh Root to Node-1 Attenuators
<input type="checkbox"/> Calibrate Mesh Node-2 Attenuators	<input type="checkbox"/> Calibrate Mesh Node-1 to Node-2 Attenuators	<input type="checkbox"/> Calibrate Mesh Root to Node-2 Attenuators
<input type="checkbox"/> 6.1.1 Receiver Sensitivity	<input type="checkbox"/> 6.2.6 Latency	<input type="checkbox"/> 6.4.2 Multiple Assoc Stability
<input type="checkbox"/> 6.2.1 Maximum Connection	<input type="checkbox"/> 6.2.7 Quality of Service	<input type="checkbox"/> 6.4.3 Downlink MU-MIMO
<input checked="" type="checkbox"/> 6.2.2 Maximum Throughput	<input type="checkbox"/> 6.3.1 Range Versus Rate	<input type="checkbox"/> 6.4.4 Multicast
<input type="checkbox"/> 6.2.3 Airtime Fairness	<input checked="" type="checkbox"/> 6.3.2 Spatial Consistency	<input type="checkbox"/> 6.5.1 Long Term Stability
<input type="checkbox"/> 6.2.4 Dual-Band Throughput	<input type="checkbox"/> 6.3.3 AX Peak Performance	<input type="checkbox"/> 6.5.2 AP Coexistence
<input type="checkbox"/> 6.2.5 Bi-Directional Throughput	<input type="checkbox"/> 6.4.1 Multiple STAs Performance	<input type="checkbox"/> 6.5.3 Automatic Channel Selection
<input type="checkbox"/> 8.1.1 Mesh Backhaul RvR	<input type="checkbox"/> 8.1.2 Mesh Backhaul Node-2 RvR	<input type="checkbox"/> 8.2.1 Mesh Roam Time

  
   
 Another Iteration   
 Pause  

12. When the test is complete, click the **Save HTML** button to save an HTML report and generate the PDF. The PDF file will be linked from the HTML page. Another option is to click 'Save PDF' and the browser will be directed to open the pdf file directly. Please see this [passing example TR-398 Issue 2 Maximum Throughput Test Report](#) .