

## CT314 Low Power LANforge-FIRE Traffic Generator

The CT314 is a low-power and affordable appliance with a single 10/100 Ethernet port and one Broadcom 802.11b/g/n Wireless interface. It is targeted at users who wish to have an inexpensive appliance that can be left at remote sites for network monitoring and lower speed testing. The maximum throughput is about 90Mbps bi-directional wired. Wireless throughput is steady at 38Mbps and can peak at 48Mbps. The CT314 is based on the Raspberry PI B version 3 platform, running the Ubuntu Server OS. While it is capable of displaying a Linux desktop and LANforge GUI, the CT314 omits these items to save resources in the default install. The CT314 has no moving parts and is about the size of a deck of cards. It has HDMI, USB Keyboard, and Mouse interfaces for easy console/desktop access to the system. VoIP support is priced separately. Please communicate your preferences to your sales representative. No additional hardware or software is required, but you need a separate PC to run the LANforge GUI for easy management of the LANforge system.

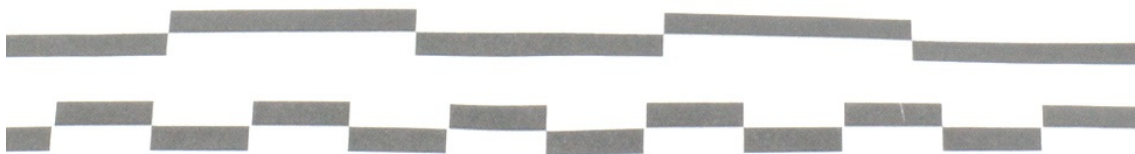

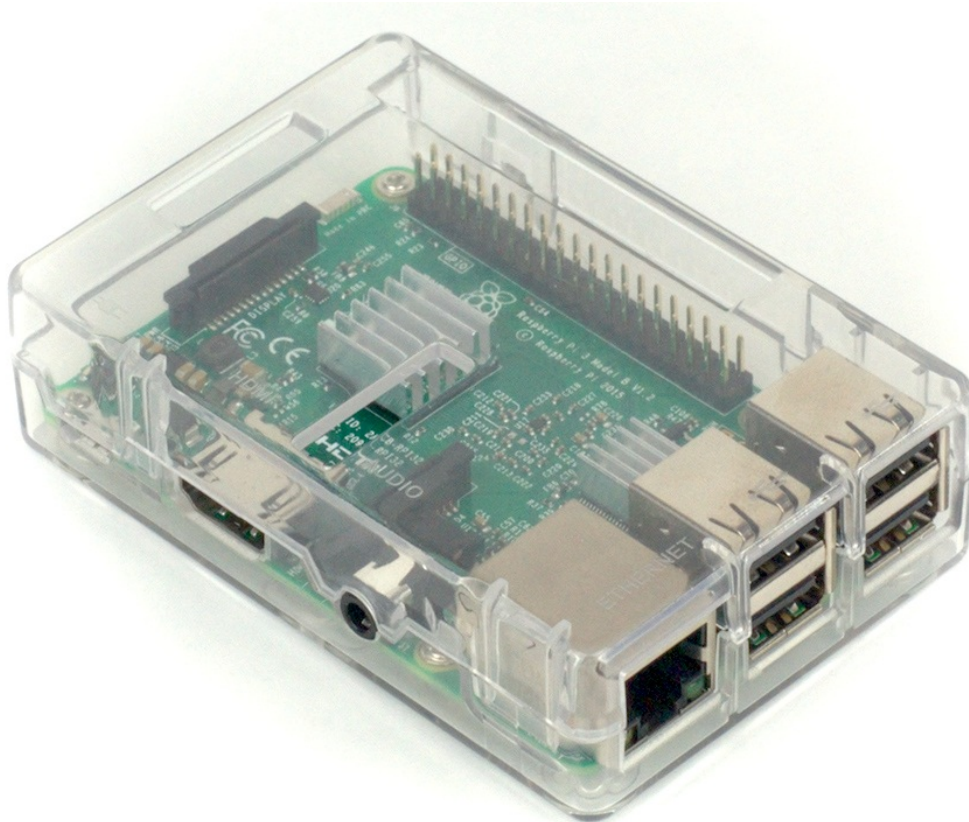
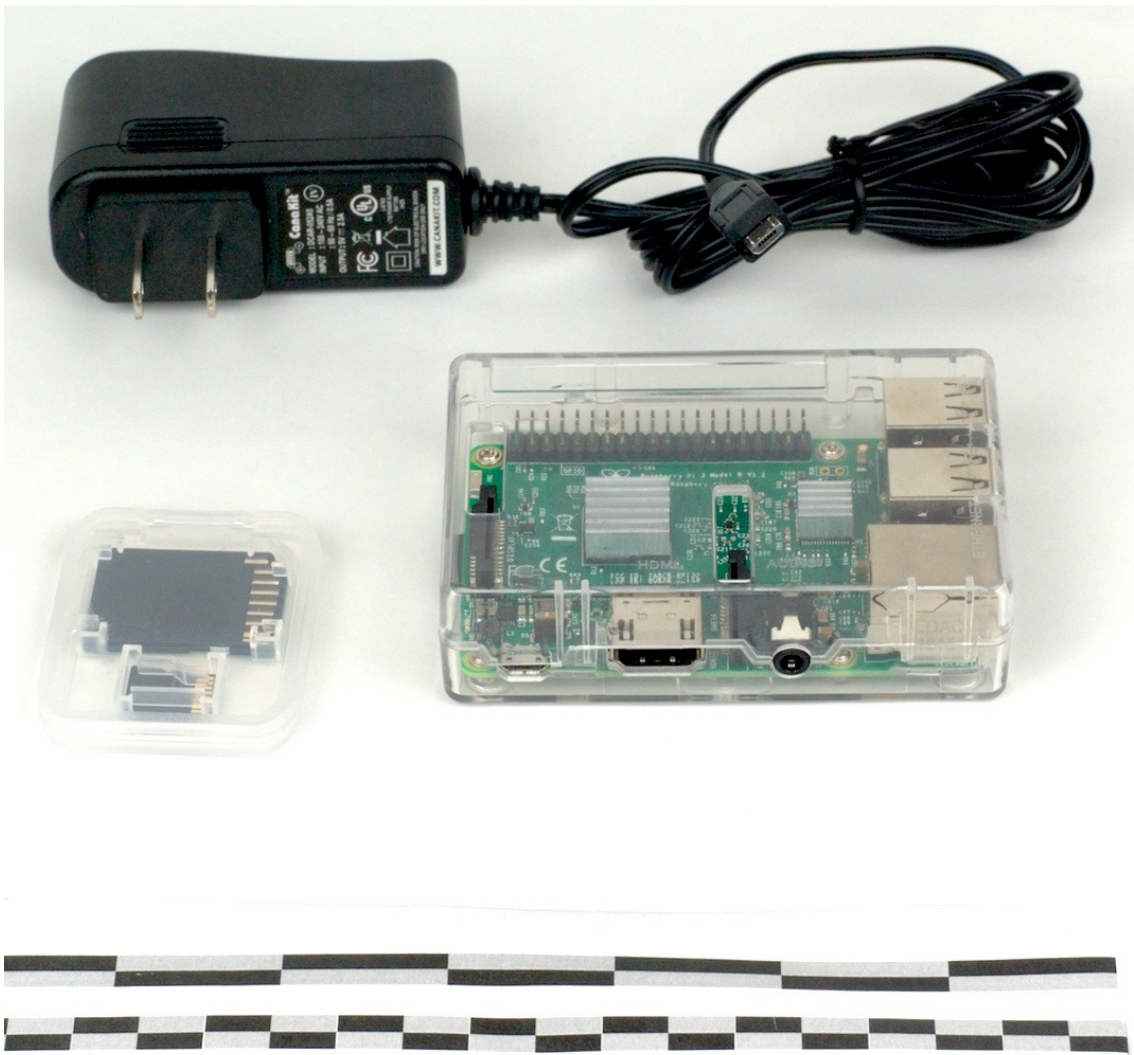

NOTE: This product may have a different hardware configuration than the system pictured above.  
Refer to your official quote for details.

Candela Technologies Inc., 2417 Main Street, Suite 201, P.O. Box 3285, Ferndale, WA 98248, USA  
www.candelatech.com | sales@candelatech.com | +1 360 380 1618

### Example Network Diagram

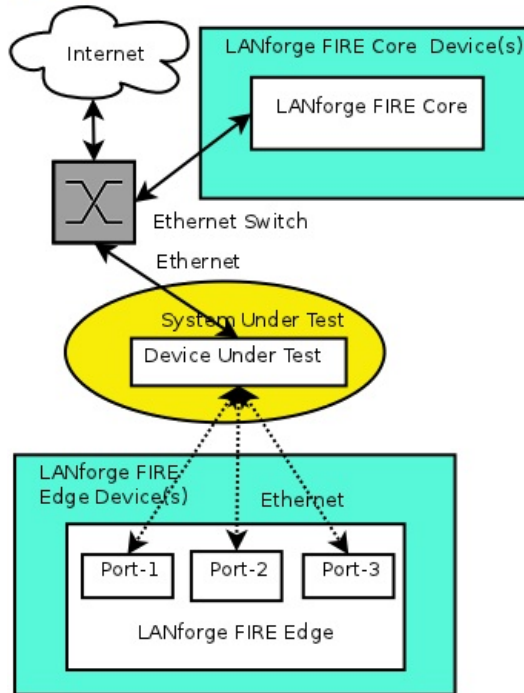

LANforge FIRE supports multiple Ethernet interfaces. To the System Under Test, it appears as if each interface is a separate PC or network appliance generating independent stateful traffic streams.

Thousands of 802.1Q and MAC-VLAN virtual interfaces are also supported. LANforge can send traffic between any two interfaces, including two interfaces on the same machine. Each physical and virtual interface can be configured on the same, or on different IP subnets.

In the configuration on the left, the LANforge FIRE Core can be one interface and act as the server. The LANforge FIRE Edge can be other interfaces on the same system. It is also valid to use multiple LANforge systems configured to act as a single realm. Using multiple systems can increase total throughput and is necessary when endpoints are physically far apart.

## Quick Start Guide

1. Connect Ethernet port to network under test. This will also be the management network. If connecting directly to a PC, an Ethernet cross-over cable should be used. Or, connect HDMI, Keyboard, and Mouse to the chassis and manage it locally.
2. Connect power plug to a standard US or European AC power source. Also, a micro-usb cable connected to a PC is normally enough to power the CT314.
3. If managing remotely, install the LANforge-GUI on a separate management PC or Laptop. Windows and Linux GUIs are supported; Select the correct one from the CDROM or Candela Technologies Download page and install it.
4. The CT314 should now boot. If DHCP is enabled on the Management network, the CT314 will automatically acquire an IP address. If DHCP is not available, the IP address will be set to 192.168.1.101 by the LANforge scripts.
5. Start the LANforge-GUI on the management PC, and click the 'Discover' button. It should find the CT314 appliance and add the IP address to the drop-down box in the Connect widget. Press 'Connect' and you will be connected to the CT314.
6. The CT314 is normally used in resource-only mode. In that case, the user will need to ssh or console into the system and configure the realm, resource-id, and perhaps a few other options using the /home/lanforge/lfconfig script. The GUI should not normally be connected to a resource machine, but should instead be connected to the manager machine.

- 7. The CT314 has three pins available for serial console. Serial console cable is not included. [Learn about connecting via serial cable.](#)

Candela Technologies Inc., 2417 Main Street, Suite 201, P.O. Box 3285, Ferndale, WA 98248, USA  
www.candelatech.com | sales@candelatech.com | +1 360 380 1618

## LANforge-FIRE Related Screen Shots

### Layer 3 (Ethernet, UDP, TCP) Connections

LANforge Manager Version(5.2.13)

Control Reporting Tear-Off Info Plugins

Stop All Restart Manager Refresh HELP

Attenuators File-I/O Layer-4 Test Mgr Test Group Resource Mgr Event Log Alerts Port Mgr Messages

Status Layer-3 L3 Endps WanLinks

Rpt Timer: fast (1 s) Go Test Manager all Select All Start Stop Quiesce Clear

View 0 - 200 Display Create Modify Delete

Cross Connects for Selected Test Manager

Name	Type	State	Pkt Rx A → B	Pkt Rx A ← B	Rate A → B	Rate A ← B	Rx Drop % A	Rx Drop % B	Drop Pkts A	Drop Pkts B	Avg RTT
xcdx-1	LF/UDP	Run	17,294	17,549	9,998,239	9,997,437	0	0	0	0	1
xcdx-10	LF/UDP	Run	17,377	17,716	9,997,632	9,996,340	0	0	0	0	0
xcdx-2	LF/UDP	Run	17,548	17,802	9,997,351	9,996,964	0	0	0	0	0
xcdx-3	LF/UDP	Run	17,633	17,802	9,997,891	9,996,964	0	0	0	0	0
xcdx-4	LF/UDP	Run	17,633	17,802	9,997,891	9,996,964	0	0	0	0	1
xcdx-5	LF/UDP	Run	17,718	17,036	9,997,947	9,992,326	0	0	0	0	1
xcdx-6	LF/UDP	Run	17,718	17,044	9,997,947	9,997,018	0	0	0	0	1
xcdx-7	LF/UDP	Run	17,718	17,044	9,997,947	9,997,018	0	0	0	0	1
xcdx-8	LF/UDP	Run	17,718	17,044	9,997,947	9,997,516	0	0	0	0	1

Logged in to: 192.168.100.26:4002 as: Admin

### Layer 3 Create/Modify Screen

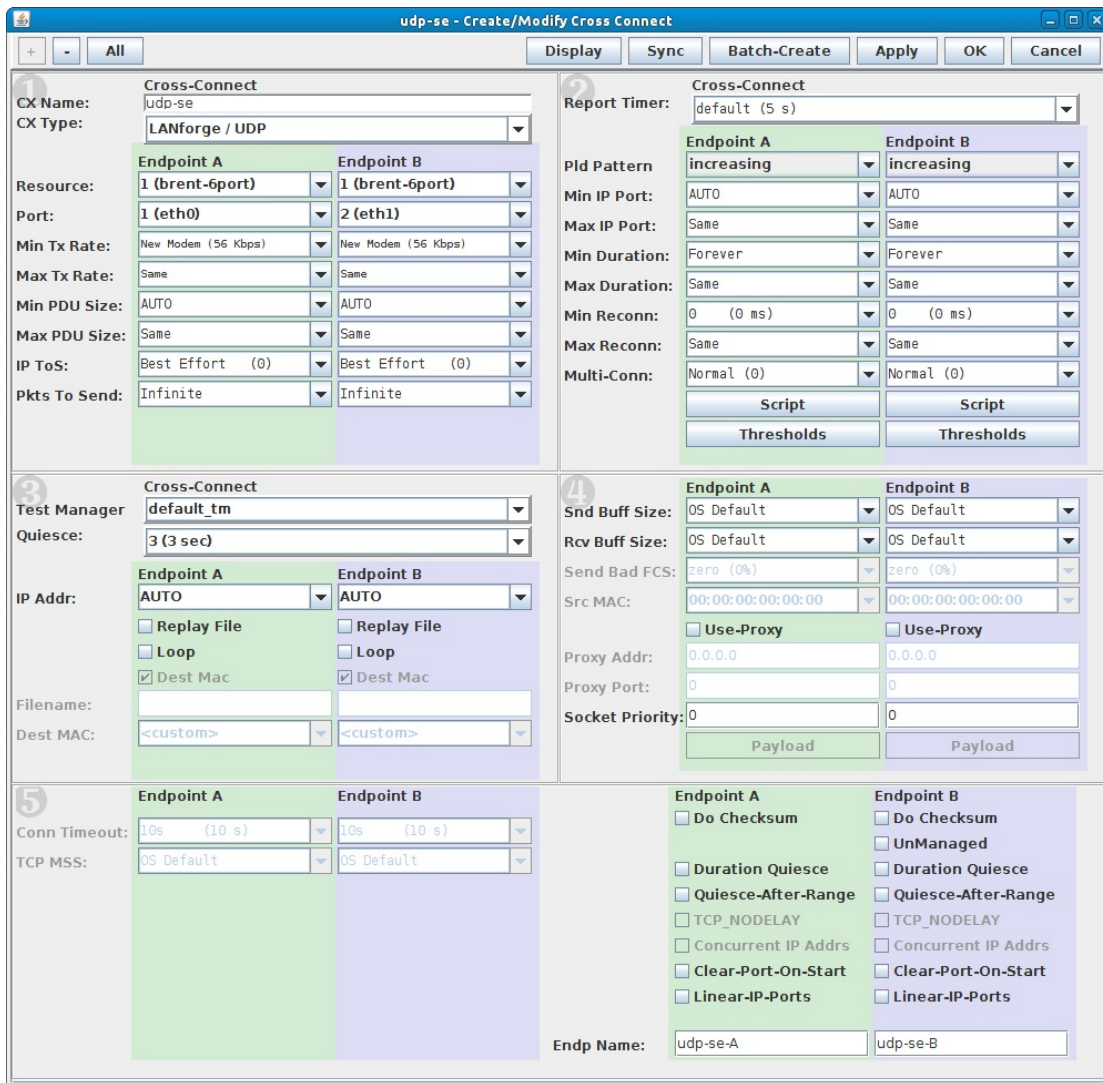

Candela Technologies Inc., 2417 Main Street, Suite 201, P.O. Box 3285, Ferndale, WA 98248, USA  
 www.candelatech.com | sales@candelatech.com | +1 360 380 1618

## Software Features

1. Supports real-world protocols:
  1. Layer 2: Raw-Ethernet.
  2. 802.1Q VLANs.
  3. Layer 3: IPv4, IPv6, UDP/IP, IGMP Multicast UDP, TCP/IP.
  4. Layer 4-7: FTP, HTTP, HTTPS, TFTP, SFTP, SCP
  5. Layer 4-7: TELNET, PING, DNS, SMTP, NMAP (via add-on script).
2. Supports up to 1000 concurrent TCP connections with base license package.
3. The CT314 is able to generate 40Mbps or more, depending on protocols mix and speed of the network under test. Supports at least 10 VoIP (SIP, RTP) calls if appropriate licenses are purchased. G.729 codec is NOT supported.
4. Supports real-world compliance with ARP protocol.
5. Supports ToS (QoS) settings for TCP/IP and UDP/IP connections.
6. Uses publicly available Linux and Windows network stacks for increased standards compliance.
7. Utilizes libcurl for FTP, HTTP and HTTPS (SSL), TFTP and SCP protocols.
8. Supports custom command-line programs, such as telnet, SMTP, and ping.

9. Comprehensive traffic reports include: Packet Transmit Rate, Packet Receive Rate, Packet Drop %, Transmit Bytes, Receive Bytes, Latency, Jitter, various Ethernet driver level counters, and much more.
10. Supports generation of reports that are ready to be imported into your favorite spread-sheet.
11. Allows packet sniffing and network protocol decoding with the integrated **Wireshark** protocol sniffer.
12. GUI runs as Java application on Linux, MAC and Microsoft Operating Systems (among others).
13. GUI can run remotely, even over low-bandwidth links to accommodate the needs of the users.
14. Central management application can manage multiple units, tests, and testers simultaneously.
15. Includes easy built-in scripting for iterating through rates and packet sizes, with automated reporting. Also supports scriptable command line interface (telnet) which can be used to automate test scenarios. Perl libraries and example scripts are provided!
16. Automatic discovery of LANforge data generators simplifies configuration of LANforge test equipment.
17. LANforge traffic generation/management software is supported on Linux and MS Windows.

---

Candela Technologies Inc., 2417 Main Street, Suite 201, P.O. Box 3285, Ferndale, WA 98248, USA  
www.candelatech.com | sales@candelatech.com | +1 360 380 1618

## Hardware Specification

1. **Raspberry PI 3**: Economy Appliance with no moving parts.
2. Operating System: Ubuntu Linux.
3. 10/100 Ethernet port. 802.11n 2.4ghz WiFi.
4. 1.2 Ghz quad-core ARM processor.
5. HDMI for video, USB for keyboard/mouse for console management & initial configuration.
6. 1 GB RAM.
7. 16+ GB SD card to act as 'hard drive'.
8. Larger SD card options available.
9. Micro-USB power adapter included.
10. Weight: less than 1 pound.
11. Dimensions: Small!
12. Operating Temperature: 0 ~ 40°C.
13. Operating Humidity: 10 ~ 90%.
14. Certification: CE/FCC.
15. Hardware supports about 90Mbps bi-directional Ethernet throughput, 60+ VOIP calls, 38Mbps one-way WiFi

List Price: \$595    List Price with 1 Year support (17%): \$696

---

## Additional Feature Upgrades

Unless otherwise noted in the product description, these features usually cost extra:

- WanPaths (LANforge-ICE feature set)
- Virtual Interfaces: MAC-VLANs, 802.1Q VLANs, WiFi stations, etc
- FIRE Connections: Base FIRE license includes 1000 active connections.
- LANforge-ICE Network Emulation.
- VOIP: Each concurrent call over the included package requires a license.
- **VoIP-Mobile Audio Quality Testing using POLQA/PESQ.**

- Mobile-Mobile Audio Quality Testing using POLQA/PESQ.
- Armageddon: Each pair of ports requires a license if not already included.
- RF Chambers for WiFi testing.
- External battery pack: 12+ hours for CT520, CT523, CT92X and other platforms.

---

Candela Technologies Inc., 2417 Main Street, Suite 201, P.O. Box 3285, Ferndale, WA 98248, USA  
www.candelatech.com | sales@candelatech.com | +1 360 380 1618

Last modified: Fri Apr 12 15:32:55 PDT 2024